

Einwanddosen dünnwandig

Single-walled jars | Pots simple parois



CARE-LIGHT-LINE



SOFT-LIGHT-LINE



SMOOTH-LIGHT-LINE

STANDARD-LIGHT-LINE



EINWANDDOSEN DÜNNWANDIG | Single-walled jars | Pots simple parois

DIMENSIONEN | Dimensions | Dimensions

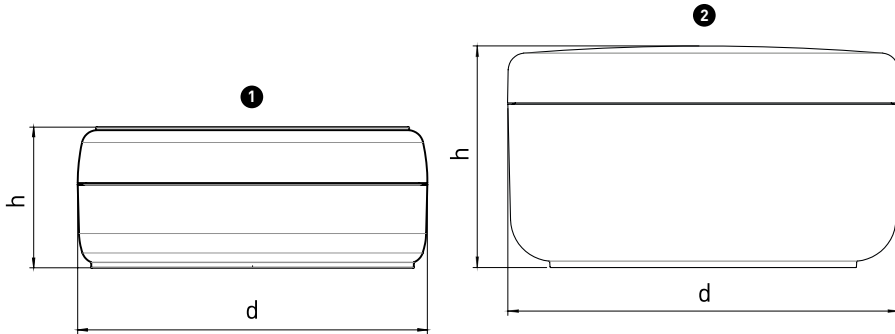

DECKELVARIANTEN | Optional lids | Variantes de couvercle

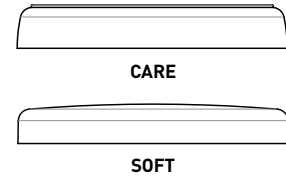

d = MAX. DURCHMESSER | Max. diameter | Diamètre max.
h = GESAMTHÖHE | Overall height | Hauteur totale

MATERIAL | Material | Matière

UNTERTEIL | Jar | Pot: **PP**
SCHRAUBDECKEL | Lid | Couvercle à vis: **PP**

INDIVIDUELLE DEKORATION

Einfärbung, Druck, Prägung, Lackierung und Metallisierung.

CUSTOMIZATION

Coloured material, printing, hot foil stamping, lacquering and metallization.

DÉCORATION PERSONNALISÉE

Sérigraphie, gravure, marquage à chaud, laquage et métallisation.

TECHNISCHE DATEN | Technical details | Spécifications techniques

NENNVOLUMEN Volume Volume ml	DOSENUNTERTEIL Jar Pot				SCHRAUBDECKEL Lid Couvercle à vis				EINLAGE Liner Joint	AUFPLAGE Disc Opercule	SIEGELRAND Sealing border Bord de scellage	DICHTLIPPE Sealing rim Lèvre d'étanchéité	DIMENSIONEN Dimensions Dimensions (mm)	
	NR. No. N°	MATERIAL Material Matière	OBERFLÄCHE Surface Aspect		SERIE Series Série	MATERIAL Material Matière	OBERFLÄCHE Surface Aspect						d	h
			GLATT smooth lisse	MATT matt mat			GLATT smooth lisse	MATT matt mat						
150	1 3898	PP	•		CARE ¹	PP	•			•		90	37	
250	2 3457	PP	•		SOFT	PP	•			•		92	53	
	2 3580	PP		•	SOFT	PP	•			•		92	53	

¹ Stapelbar | Stackable | Avec rainure d'empilage

EINWANDDOSEN DÜNNWANDIG | Single-walled jars | Pots simple parois

DIMENSIONEN | Dimensions | Dimensions

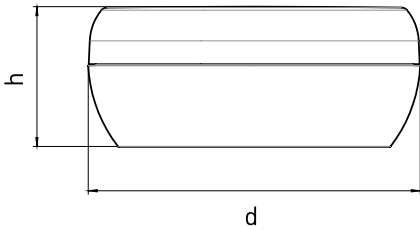

d = MAX. DURCHMESSER | Max. diameter | Diamètre max.
h = GESAMTHÖHE | Overall height | Hauteur totale

MATERIAL | Material | Matière

UNTERTEIL | Jar | Pot: **PP**
SCHRAUBDECKEL | Lid | Couvercle à vis: **PP**

INDIVIDUELLE DEKORATION

Einfärbung, Druck, Prägung, Lackierung und Metallisierung.

CUSTOMIZATION

Coloured material, printing, hot foil stamping, lacquering and metallization.

DÉCORATION PERSONNALISÉE

Sérigraphie, gravure, marquage à chaud, laquage et métallisation.

TECHNISCHE DATEN | Technical details | Spécifications techniques

NENNVOLUMEN Volume Volume ml	DOSENUNTERTEIL Jar Pot				SCHRAUBDECKEL Lid Couvercle à vis				EINLAGE Liner Joint	AUFPLAGE Disc Opercule	SIEGELRAND Sealing border Bord de scellage	DICHTLIPPE Sealing rim Lèvre d'étanchéité	DIMENSIONEN Dimensions Dimensions (mm)	
	NR. No. N°	MATERIAL Material Matière	OBERFLÄCHE Surface Aspect		SERIE Series Série	MATERIAL Material Matière	OBERFLÄCHE Surface Aspect						d	h
			GLATT smooth lisse	MATT matt mat			GLATT smooth lisse	MATT matt mat						
50	3947	PP	•		SMOOTH-LIGHT	PP	•			•		65	28	
150	3904	PP	•		SMOOTH-LIGHT	PP	•			•		94	40	
200	3905	PP	•		SMOOTH-LIGHT	PP	•			•		94	49	
250	3906	PP	•		SMOOTH-LIGHT	PP	•			•		94	58	

EINWANDDOSEN DÜNNWANDIG | Single-walled jars | Pots simple parois

DIMENSIONEN | Dimensions | Dimensions

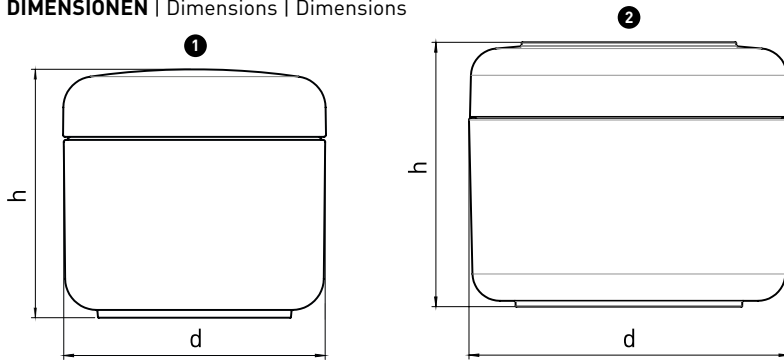

d = MAX. DURCHMESSER | Max. diameter | Diamètre max.
h = GESAMTHÖHE | Overall height | Hauteur totale

MATERIAL | Material | Matière

UNTERTEIL | Jar | Pot: **PE, PP**
SCHRAUBDECKEL | Lid | Couvercle à vis: **PE, PP**

AUFLAGE | Disc | Opercule: **PP**

INDIVIDUELLE DEKORATION

Einfärbung, Druck, Prägung, Lackierung und Metallisierung.

CUSTOMIZATION

Coloured material, printing, hot foil stamping, lacquering and metallization.

DÉCORATION PERSONNALISÉE

Sérigraphie, gravure, marquage à chaud, laquage et métallisation.

TECHNISCHE DATEN | Technical details | Spécifications techniques

NENNOLUMEN Volume Volume ml	DOSENUNTERTEIL Jar Pot				SCHRAUBDECKEL Lid Couvercle à vis				EINLAGE Liner Joint	AUFLAGE Disc Opercule	SIEGELRAND Sealing border Bord de scellage	DICHTLIPPE Sealing rim Lèvre d'étanchéité	DIMENSIONEN Dimensions Dimensions (mm)	
	NR. No. N°	MATERIAL Material Matière	OBERFLÄCHE Surface Aspect		SERIE Series Série	MATERIAL Material Matière	OBERFLÄCHE Surface Aspect						d	h
			GLATT smooth lisse	MATT matt mat			GLATT smooth lisse	MATT matt mat						
150	1 3305	PP	•		SOFT	PP	•	•	•	•		67	65	
	2 3809	PP		•	SOFT LIGHT ¹	PP		•	•	•		82	57	
200					SOFT LIGHT ¹	PE		•	•	•		82	57	
	2 3840 ²	PP		•	SOFT LIGHT ¹	PP		•		•		82	57	
					SOFT LIGHT ¹	PE		•		•		82	57	
	2 3750 ³	PP		•	SOFT LIGHT ¹	PP		•	•	•		82	69	
250					SOFT LIGHT ¹	PE		•	•	•		82	69	
	2 3787	PE		•	SOFT LIGHT ¹	PP		•	•	•		82	69	
					SOFT LIGHT ¹	PE		•	•	•		82	69	
	2 3790	PP		•	SOFT LIGHT ¹	PP		•	•	•		82	69	
					SOFT LIGHT ¹	PE		•	•	•		82	69	

¹ Stapelbar | Stackable | Avec rainure d'empilage

² Dosenhals 1 mm höher als bei 3809 | Jar neck height increased by 1 mm compared with 3809 | Col du pot: + 1 mm par rapport à 3809

³ PP- und Recycling-Kennzeichnung am Dosenboden | PP and recycling mark on the bottom | PP et sigle recyclage sur le fond du pot

EINWANDDOSEN DÜNNWANDIG | Single-walled jars | Pots simple parois

DIMENSIONEN | Dimensions | Dimensions

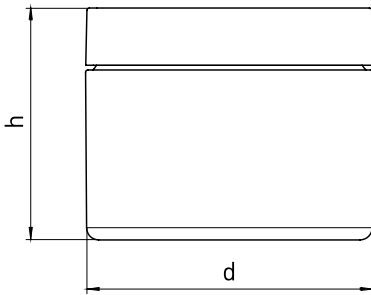

d = MAX. DURCHMESSER | Max. diameter | Diamètre max.
h = GESAMTHÖHE | Overall height | Hauteur totale

DECKELVARIANTEN | Optional lids | Variantes de couvercle



SOFT



STANDARD



STANDARD-LIGHT S

MATERIAL | Material | Matière

UNTERTEIL | Jar | Pot: **PP**
SCHRAUBDECKEL | Lid | Couvercle à vis: **SAN, PP**

INDIVIDUELLE DEKORATION

Einfärbung, Druck, Prägung, Lackierung und Metallisierung.

CUSTOMIZATION

Coloured material, printing, hot foil stamping, lacquering and metallization.

DÉCORATION PERSONNALISÉE

Sérigraphie, gravure, marquage à chaud, laquage et métallisation.

TECHNISCHE DATEN | Technical details | Spécifications techniques

NENN-VOLUMEN Volume Volume ml	DOSENUNTERTEIL Jar Pot				SCHRAUBDECKEL Lid Couvercle à vis				EINLAGE Liner Joint	AUFPLAGE Disc Opercule	SIEGELRAND Sealing border Bord de scellage	DICHTLIPPE Sealing rim Lèvre d'étanchéité	DIMENSIONEN Dimensions Dimensions (mm)	
	NR. No. N°	MATERIAL Material Matière	OBERFLÄCHE Surface Aspect		SERIE Series Série	MATERIAL Material Matière	OBERFLÄCHE Surface Aspect						d	h
			GLATT smooth lisse	MATT matt mat			GLATT smooth lisse	MATT matt mat						
100	3337	PP	•		SOFT	SAN	•	•	•	•			61	54
					STANDARD	PP	•		•	•			61	50
	3890	PP	•		STANDARD-LIGHT S ¹	PP	•						62	48
		PP	•		STANDARD	PP	•						62	48
200	3891	PP	•		STANDARD-LIGHT S ¹	PP	•						76	60

¹ Stapelbar | Stackable | Avec rainure d'empilage

hopf

www.hopf.de

Interesse? Fragen? Wir sind gerne für Sie da!

Hopf Packaging GmbH

Wemdinger Str. 13 | D-86720 Nördlingen
(Besucher-Anfahrt über Reutheweg)

Telefon +49 9081-806-0

Telefax +49 9081-806
-200 Vertrieb
-203 Versand
-271 Einkauf

E-Mail info@hopf.de

Web www.hopf.de

QR-Code scannen &
Website besuchen!

